



2000 Series
Direct & Indirect Calorifiers

Installation, Operating &
Maintenance Manual

VERY IMPORTANT - PLEASE READ CAREFULLY

Introduction	1	Page 1
Series 2000		Page 1
General Requirements		Page 1
Water Supply		Page 1
Installation	2	Page 1 - 4
General		Page 2 - 3
Direct Units Installation		Page 3
Electrical Installation & Operation		Page 3
Indirect Units		Page 4
Commissioning	3	Page 5
Filling, Checks, Direct Units and Indirect Units		Page 5
Operational	4	Page 6
User Instructions, Faults and Flow Performance		Page 6
Maintenance	5	Page 7
Optimum Performance, Fault Finder and Spares		Page 7
Drawings & Diagrams	6	Page 8 - 9
Wiring for Single and Twin Stage Control Diagrams		Page 8
Piping Diagram		Page 9

1. Introduction

Series 2000

The Series 2000 calorifier is suitable for installation in an un-vented system and will accept water directly from the cold mains supply.

It is supplied complete with expansion kit and safety controls.

Direct units are fitted with an electric immersion heater(s) with control thermostat(s). A manual reset overtemperature thermostat may be necessary.

Indirect units may be fitted with an electric immersion heater as a back up to the indirect coil. A cylinder thermostat and a separate manual reset over-temperature thermostat will be required.

NOTE: On indirect units, it is the users responsibility to provide a suitable 2 port motorised valve in the primary flow circuit for over temperature protection.

General Requirements

Important: Please read and understand these instructions before installing the water heater. Incorrect installation will invalidate the guarantee.

A competent person who is familiar with the current version of the building regulations should install the heater.

As soon as you receive the unit check that all the components for the Series 2000 are contained in the package. Failure to do so will inhibit the supply of missing components.

The following components are supplied loose, as standard:

- Pressure reducing valve
- Non return valve
- Expansion relief valve
- Expansion tank
- Combined temperature/pressure relief valve(s)
- Drain cock
- Cylinder thermostat and manual reset over temperature thermostat (Indirect units)

The following items are supplied fitted, as standard:

- Immersion Heater, when required.

Water Supply

The mains water supply to the property will be supplying both the hot and cold water requirements simultaneously.

It is recommended that the maximum water demand be assessed and the water supply be checked to ensure that this demand can be satisfactorily met.

NOTE A high mains water pressure will not always guarantee high flow rates. Water quality can seriously affect the life of the heater.

Failure of the heater due to the accumulation of solid material and lime deposits is not covered by the warranty.

If water quality warrants, a properly maintained lime inhibitor or water softener should be installed with this unit.

It is the owner's responsibility to properly maintain the equipment.

Outlet/Terminal fittings

The water heater can be used in conjunction with most types of terminal fittings.

It is advantageous in many mixer showers to have balanced hot and cold water supplies.

Refer to the drawings at the end of the instructions for connection locations.

Outlets situated higher than the cylinder will give outlet pressures lower than that at the heater.

A 10metre height difference will result in a 1 bar pressure reduction at the outlet fitting.

2. Installation General

General Installation

Lifting

Lifting lugs are provided at the top of the calorifier. The cladding is plasticised and may be damaged by the use of chains or straps.

Care should be taken in moving the Calorifier to prevent damage to the fittings. Indirect units should not be shaken as this could damage the internal coil.

Foundations

Calorifiers should be mounted on prepared foundations which are level. Even a slight tilt can cause an airlock inside the tubes, which will affect the flow of heat.

Vertical calorifiers are suitable for floor mounting, and can be located virtually anywhere on site, provided the tundish and discharge pipe (supplied by others) can be correctly installed.

Ensure that the floor is of sufficient strength to support the “full” weight of the unit. Horizontal calorifiers are normally supported on loose cradles, which need to be positioned clear of the drain connection and leave access to any flanges for tightening of bolts.

Pipework

Ensure that all pipework is properly aligned to the vessel connections. The weight of the pipework should be taken by external supports and not by the vessel.

Allowance should be made for expansion of the pipes either by suitable bends or flexible joints. Pipe runs should be kept as short as possible for maximum economy.

Access to associated controls, immersion heaters and indirect controls should be possible for servicing and maintenance of the system.

Connections

All connections on the water heater are screwed BSP female except the primary connections on indirect models, which are plain 28mm stainless steel tube. It is recommended 28mm compression fittings be used.

Note: If solder type fittings are used in the supply pipework, the use of self-cleaning fluxes should be avoided as they can impair the operation of the safety valves in the inlet supply group.

Use TWO spanners when joining screwed connections to avoid undue torque on the calorifier fittings.

Cold Water Supply

The main supply pipe must be of equal or greater diameter than the water inlet connection to the water heater. A suitable valve should be fitted in the cold water supply to enable the heater to be isolated for draining down.

Inlet Supply Group

The components in the inlet supply group can be connected in the correct sequence anywhere on the cold water mains supply, prior to the water heater.

There is no requirement to site them close to the unit.

They may be sited at a point where the mains supply enters the premises, if this is more convenient.

Ensure that the discharge from the expansion relief valve is correctly installed and that all valves are installed with the direction of flow arrows pointing towards the heater.

Drain

All cylinders are supplied with a drain valve with a hose connection to facilitate easy draining for service purposes.

2. Installation General Cont.

General Installation Cont.

Outlet Pipework

Ideally the pipe work from the calorifier to the outlet fittings should be run in a diameter that matches the outlet connection as far as possible, with short runs of a smaller bore close to the draw off points.

Tundish and discharge pipe.

It is a requirement of building regulations that any discharge from an unvented system is safely conveyed to where it is visible but will not cause danger to persons in or about the building.

The installer should provide discharge pipes and tundishes and fit them in accordance with the building regulations.

- i) Discharge pipe must terminate in a safe, visible position.
- ii) The tundish should be within 500mm of the temperature/pressure relief valve and, wherever possible, be in a visible position.
- iii) The discharge pipe work should have a vertical fall of at least 300mm from the tundish.
- iv) The minimum discharge pipe size should be one pipe size larger than the temperature/pressure relief valve discharge port.
- v) The maximum total equivalent hydraulic resistance of the discharge pipe should not exceed that of 9 metres of straight pipe.
- vi) The discharge pipe should have a continuous fall (minimum 1:200)

Installation - Direct Units

Water heaters are fitted with either flanged immersion heater(s) that each have a control thermostat and a manual reset over-temperature thermostat, or, screwed immersion heater(s) with a control thermostat and a separate manual reset over-temperature thermostat fitted at high level in the cylinder.

Note: Where the electric heat unit is supplied as a separate unit, when fitted to the vessel the thermostats should always be mounted on top.

Electrical Installation

All electrical wiring should be carried out by a competent electrician and be in accordance with the latest I.E.E. Wiring Regulations.

The thermostats supplied have a maximum switching capability of 15 Amps/240V/1Ph. For all single-phase immersion heaters in excess of 3kW and ALL three phase immersion heaters a suitably rated interposing contactor must be installed.

A suitably rated isolator and protection fuse(s) should be fitted to protect both the load and control circuits.

Secondary circulation.

All cylinders have a return connection as standard. Suitably approved bronze circulation pumps must be used.

Warnings

- i) Under no circumstances should the temperature / pressure relief valve be removed or adjustment attempted. To do so will invalidate any guarantee or claim.
- ii) The cold water supply group components must all be fitted in the correct sequence in the mains water supply to the heater.
- iii) The discharge pipe(s) from safety valves should not be blocked or used for any other purpose.
- iv) No control or safety valves should be tampered with.

Operation

It is recommended that the control thermostat(s) be set to 60-65 deg. C and that the over-temperature thermostat be set to 80 deg. C.

DO NOT bypass the over temperature thermostat in any circumstances.

2. Installation General Cont.

Indirect Units

Indirect water heaters are fitted with a fixed coil heat exchanger.

Boiler selection

- i) The water heater is suitable for use with all forms of boiler compatible with unvented systems i.e. fitted with a temperature control thermostat.
If in doubt, consult the boiler manufacturer.
- ii) **DO NOT** use a coal or wood burning boiler as these do not have adequate thermal control for unvented systems.
- iii) The boiler used can be either an open vented type or a sealed system having a maximum primary circuit pressure of 3 barg
- iv) The primary flow from the boiler should be pumped. Gravity circulation is not recommended due to poor heating performance.
- v) The boiler flow temperature should be set at a maximum of 90°C.

Indirect cylinder control thermostat

The control thermostat should be wired in series with a suitable control valve (not supplied) in the primary circuit to give temperature control of the stored water.

Indirect over-temperature (master) thermostat

The master thermostat, mounted at high level, **MUST** be wired to a suitable 2 port motorised valve (not supplied) fitted to the primary flow of the indirect coil.

Electrical Installation

All electrical wiring should be carried out by a competent electrician and be in accordance with the latest I.E.E.

Wiring Regulations.

The control thermostat and master thermostat must be wired in series with a 2 port motorised valve installed in the primary flow, such that the power supply is interrupted should either device operate, cutting off the primary flow.

A suitable switch and fuse should be provided to give protection to the electrical wiring and components. The master thermostat **MUST NOT** be bypassed.

Immersion heater.

On models where an additional electric immersion heater has been fitted, this can be used either as an independent alternative heat source or to boost output during peak loads. The immersion heater should be fitted with the thermostats to the top and wired in accordance with section 4.0 above.

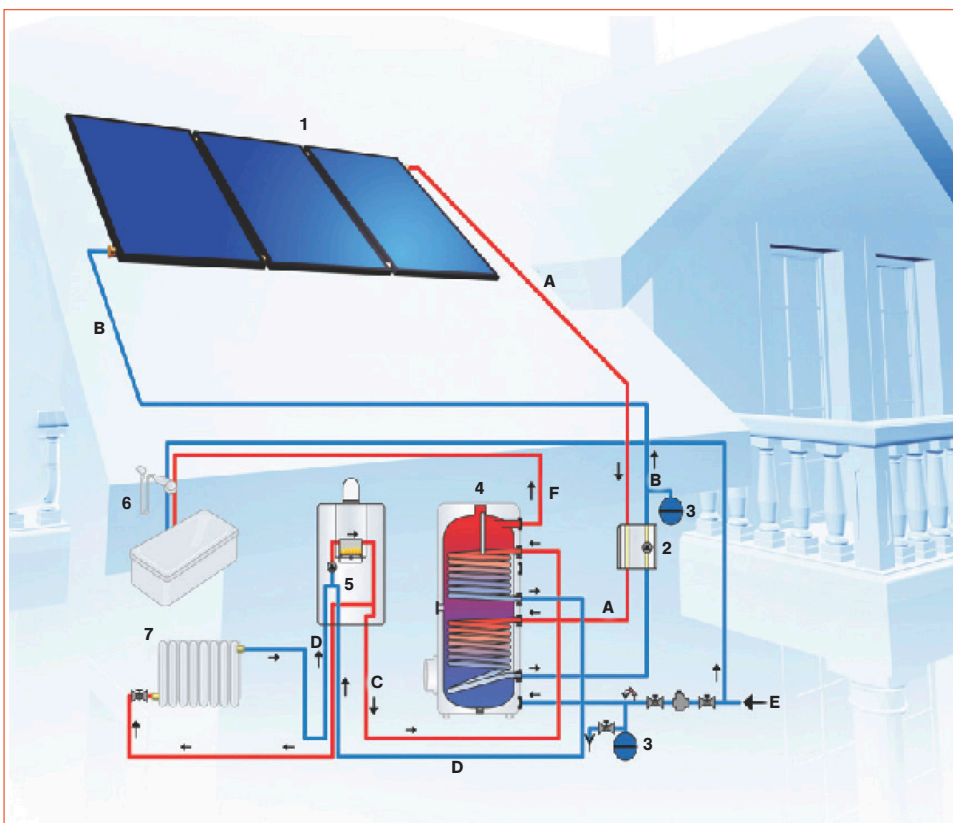

1	Solar Panel
2	Double Pump station
3	Expansion Vessel
4	Hot Water Cylinder
5	Boiler
6	Hot water Domestic Supply
7	Heating System

A	Flow Pipe (Hot Glycol) Solar
B	Return Pipe (Cold Glycol) Solar
C	Flow Pipe from Boiler
D	Return Pipe from Boiler
E	Cold Water feed
F	Hot Water Supply to Tap

3. Commissioning

Commissioning

Filling

Ensure that all fittings are in place and tightened.

- i) Check that the drain valve is closed.
- ii) Open the tap furthest from the storage cylinder.
- iii) Open the valve in the cold water supply and fill the system at a steady rate to allow entrapped air to escape through the opened tap. When water issues from the tap, allow the water to run for a few minutes to flush through any dirt and extraneous material.
- iv) Open successive hot taps to purge any remaining air from the system. When satisfied that the system is free of air close the taps.
- v) Check all connections for leaks and rectify as necessary.

Check the operation of the safety valves

- i) Manually open, for a few seconds, the Temperature & Pressure Relief Valve, situated on the top of the Series 2000 cylinder. Check that the discharged water runs freely away through the tundish and discharge pipe work.
- ii) Repeat for the expansion valve, which should have been fitted in the cold water supply on installation.

Check the charge pressure on the expansion tank

The separate expansion tank supplied with the water heater was pre charged before despatch from the factory.

The charge pressure is 3.5barg (50psi) for 40, 60 and 80 litre expansion vessels and 2.1 barg (30psi) for 100, 200 and 300 litre expansion vessels.

A tyre pressure gauge or a special press on gauge can be used, but care must be taken to ensure that they are clean and that no dirt is introduced into the charging/test point.

- i) Turn water supply to water heater off
- ii) Open a hot water tap.

The above two actions reduce the system pressure to atmospheric so that the vessel charge pressure, and not the system pressure, can be taken.

- iii) Remove dust cap from the Schrader valve
- iv) Measure vessel charge pressure (If necessary recharge the vessel to the correct pressure).
- v) Close the hot water tap
- vi) Turn on the water supply

Direct Units

Switch on the electrical supply to the immersion heater(s) and allow the unit to heat up.

Check that the control thermostat operates correctly.

Check that no water is discharged from either the Expansion Valve or the Temperature and Pressure relief valve, during the heating cycle.

When the desired temperature has been reached, check around all connections, as they may have slackened off due to expansion.

Indirect Units

Fill the indirect (primary) circuit in accordance with the boiler manufacturers commissioning instructions.

To ensure that the primary coil in the Series 2000 is filled, manually open the 2-port valve until the filling sequence is completed.

When the primary circuit is full release the valve to its normal position.

Switch on the boiler.

Allow the cylinder to heat up and check that the cylinder control thermostat and 2-port valve operates correctly.

Check that no water is discharged from either the Expansion Valve or the Temperature and Pressure relief valve, during the heating cycle.

When the desired temperature has been reached, check around all connections, as they may have slackened off due to expansion.

4. Operational

User Instructions

WARNINGS

If water issues arise from the temperature/pressure relief valve, switch off the electrical supply to the immersion heaters (Direct Units) or shut down the boiler (Indirect Units).

DO NOT turn off the water supply. Contact a competent installer for unvented water heaters to check the system.

DO NOT tamper with any of the safety relief valves fitted to the system. If a fault is suspected contact a competent installer.

Temperature control - Immersion heaters

The control thermostat on the immersion heater(s) can be set between 40°C and 80°C. Adjustments can only be made by removing the immersion heater cover.

DO NOT remove the cover without first switching off the electrical supply.

Indirect Units

These are fitted with a cylinder thermostat that controls a 2 port motorised valve (not supplied) in the primary circuit, and hence the temperature of the water in the storage cylinder. The thermostat can be set between 40°C and 80°C.

DO NOT remove the cover without first switching off the electrical supply.

If in any doubt consult a competent electrician.

Operational Faults

Operational faults and their possible causes are detailed in section 9.3. It is recommended that a competent person investigate faults.

The air volume within the expansion vessel will periodically require recharging to ensure any expanded water is accommodated within the system. A discharge of water intermittently from the expansion relief valve will indicate that the air volume has reduced to a point where it can no longer accommodate the expansion.

To recharge the air volume: -

The vessel can be recharged using an inert gas or dry air. Special recharging bottles, compressors (with dryers) or car foot pumps can be used. Care must be taken to ensure that they are clean and that no dirt is introduced into the charging/test point.

- i) Turn off the water supply to the water heater
- ii) Open a hot water tap to reduce system pressure to atmospheric
- iii) Remove dust cap
- iv) Recharge the vessel to the correct pressure (see section 6.3)
 - a) If the vessel has been fully deflated for some time, the membrane could have become bonded to the shell. If this has happened, it is possible to free it by using a higher charging pressure, but care must be taken in doing this, to avoid over pressurising the vessel.

Flow Performance

When initially opening hot outlets, a small surge in flow may be noticed as pressures stabilise. This is quite normal with unvented systems and does not indicate a fault.

In some areas cloudiness may be noticed in the hot water. This is due to aeration of the water. It is quite normal and will quickly clear.

- b) If the vessel cannot be recharged it must be replaced.
- v) When the vessel has been recharged the dust cap must be replaced.
- vi) Close hot water tap
- vii) Turn on the water supply

5. Maintenance

Optimum Performance

To ensure the continued optimum performance of the heater, it should be regularly maintained. This is of particular importance in hard water areas or where the water supply contains particulate matter.

Maintenance should be carried out only by a competent person. Any replacement parts used should be authorised Heatrae Industrial spare parts. It is recommended that maintenance be carried out every 12 months.

In hard water areas, consideration should be given to periodically descaling the immersion heater elements. To do this the cylinder will need to be drained.

Safety Valves

Manually operate the Temperature and Pressure relief valve for a few seconds. Check that water is discharged and that it flows freely through the tundish and discharge pipe work.

Check that the valve reseats correctly when released.

WARNING: The water discharged may be very hot.

Expansion relief valve

Repeat the above.

Clean the strainer

The strainer is incorporated within the pressure-reducing valve. To inspect and clean it, turn off the mains water supply and open the lowest hot water tap in the system to relieve the system pressure. Unscrew the black cap from the pressure reducing valve and remove. The strainer will be removed with the cap.

Wash any particulate matter from the strainer under clean running water. Replace the cap assembly, ensuring that the sealing ring is correctly fitted. **Do not** use any other type of sealant. Close the hot tap, open mains stopcock and check for leaks.

Draining

Switch off the electrical supply to the immersion heater(s) and shut down the boiler on indirect units.

Turn off the cold water supply. Attach a hosepipe to the drain valve having sufficient length to take the water to a suitable discharge point. Open the hot water tap nearest to the water heater, to relieve system pressure. Open the drain valve. If water fails to drain from the cylinder, vent the unit by manually opening the Temperature and Pressure relief valve.

Descaling. Isolate the electrical supply

Remove the cover from the immersion heater(s) and disconnect the wiring, carefully noting the wiring sequence.

Remove the immersion heater from the cylinder by using a "C" spanner (for screwed immersion heaters) or a socket spanner (for flanged immersion heaters). Carefully remove the scale from the surfaces of the elements and thermostat pockets by mechanical or chemical means. **DO NOT** use a sharp implement as damage to the element surface could be caused.

Ensure that boss threads/ flange faces are clean and replace the immersion heaters(s). Ideally a new gasket should be used.

Re-wire in the same sequence noted, before removing the immersion heater.

Refilling

DO NOT switch on the immersion heater(s) or boiler until the system has been completely refilled.

Close the drain tap and follow the filling sequence.

The electrical supply can now be switched on.

Fault Finder

IMPORTANT NOTES

- i) Servicing should only be carried out by a competent person.
- ii) Any spare parts used **MUST** be an authorised Heatrae Industrial part.
- iii) Disconnect the electrical supply before removing any access covers.
- iv) **NEVER** bypass any over temperature thermostats.
- v) Hot water can scald. Care should be taken when drawing water from the units.

Spare Parts

A range of spare parts and accessories is available for the Series 2000.

When ordering spare parts the serial number on the unit should be quoted.

6. Drawings & Diagrams

Wiring for Single Stage Control

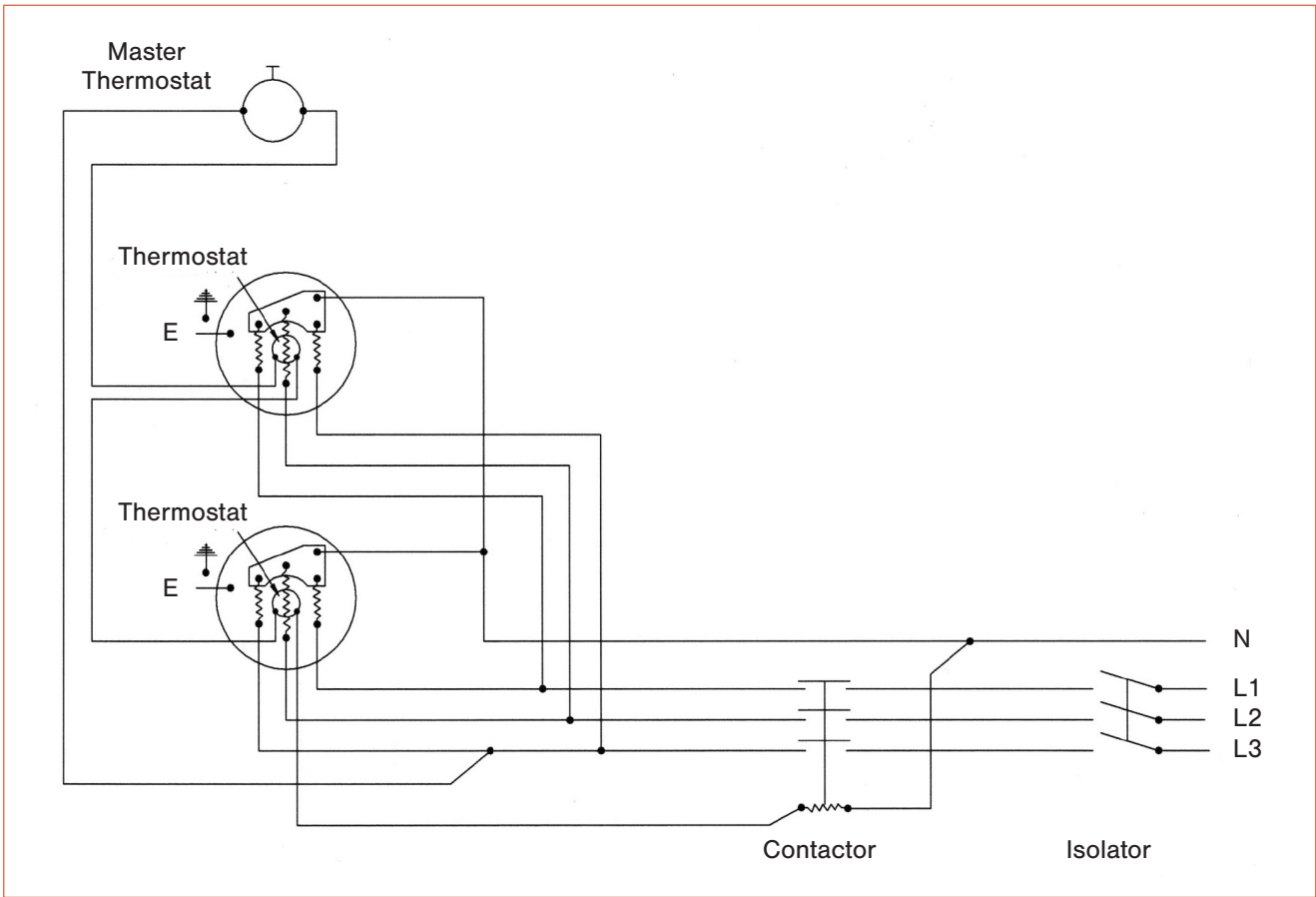

Wiring for Two Stage Control

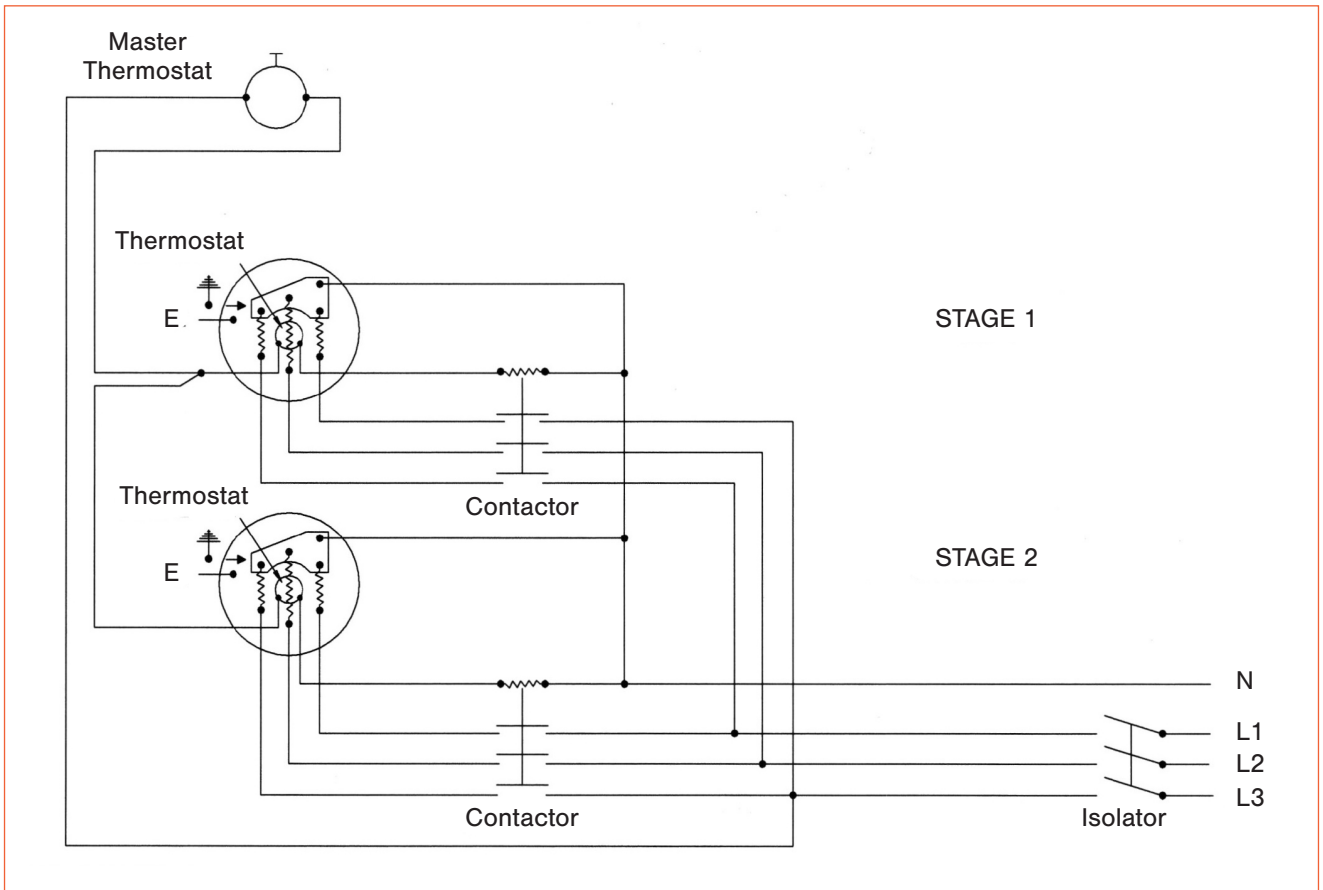

6. Drawings & Diagrams

Piping Diagram

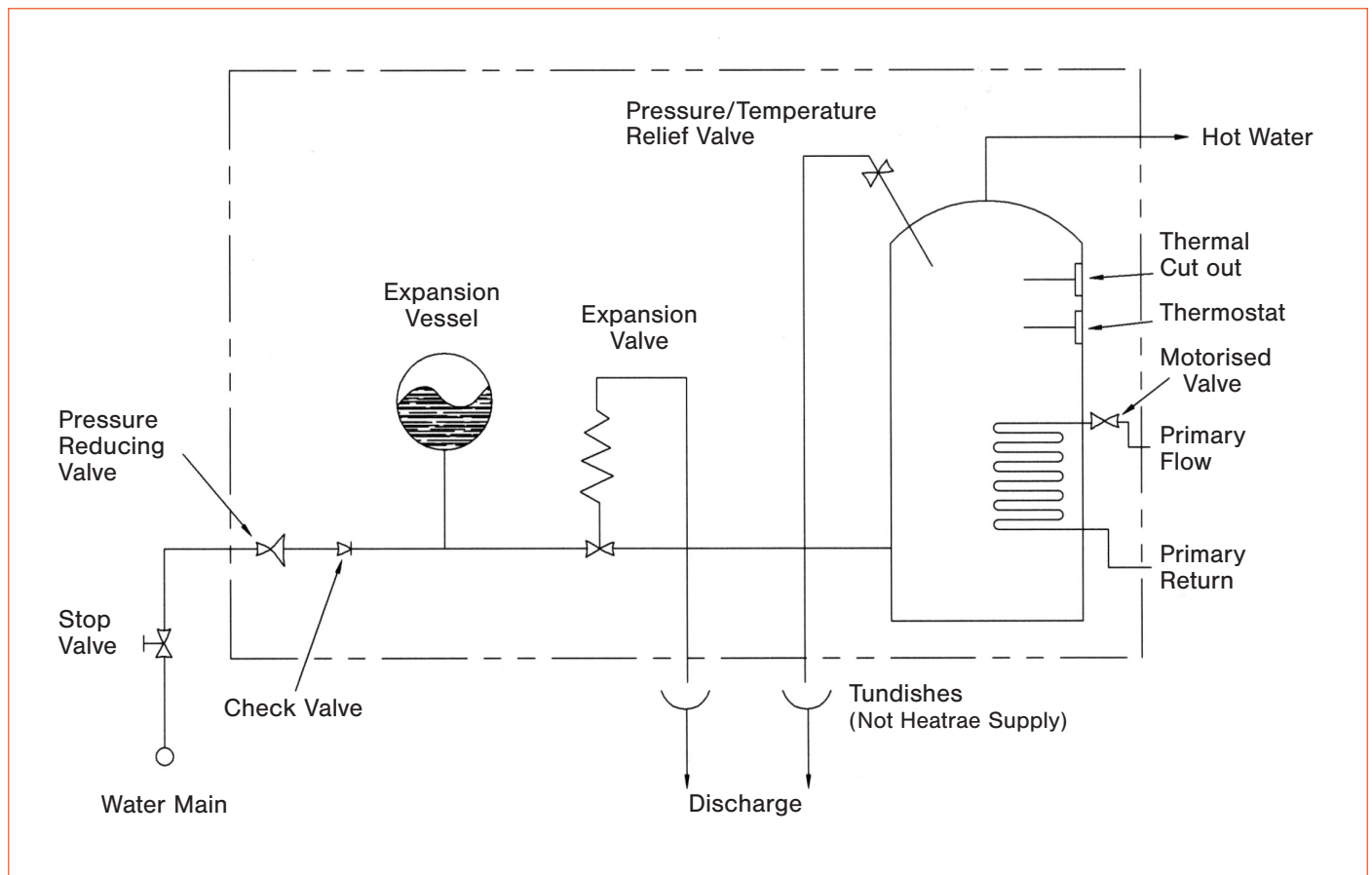



Duncombe Road,
Bradford, England BD8 9TB.

Telephone: +44 (0) 1274 490911. Email: sales@ormandygroup.com

www.ormandygroup.com